

2025 FIA CENTRAL EUROPEAN ZONE CHAMPIONSHIP

Art.1 General Conditions

1.1 General Provisions

According to FIA Appendix Z the World Council (for Karting the CIK/FIA) accepted a Central European Zone. The Zone will be made up of the following countries: Albania, Austria, Bosnia-Herzegovina, Croatia, Czech Republic, Hungary, Kosovo, North Macedonia, Malta, Montenegro, Poland, San Marino, Serbia, Slovenia and Slovakia (to be mentioned as Zone Countries).

In 2025 there will be announced Zone-Championships in Autocross, Circuit Racing (also for historic cars), Endurance, Cross-Country, Hill-Climb (also for historic cars), Karting, Rally (also for historic cars), Rallycross, Slalom, Drifting and Regularity reserved for drivers holding a valid national or international licence issued by one of the ASNs belonging to the zone. The starting permission for abroad is not obligatory.

The Zone Championship events are published on website of CEZ. For every discipline a maximum of 16 events will be listed in the calendar (one per member ASN). The final decision about the number of events counting to the Championship will be taken by the board of the FIA CEZ countries, but no additional event must be added after January 15, 2025.

If not all ASNs enter events for a Championship, the Zone-board will decide upon the events to fill up to the max. number of 16, respecting the following:

- If ASNs enter only events for a max. of 2 disciplines, the board may accept one additional event from these ASNs in these discipline Championships.
- If there are less than 10 events entered then all ASNs may forward a 2nd event for that Championship – following the CEZ board will finally decide which of these events will be accepted.
- The max. number of 16 events per discipline will never be increased by such decisions.

If necessary for exceptional reasons, a movement of events (dates and/or locations) may be applied by the home ASN during the season, but to free dates only and this must be announced at least 60 days before the start of such an event. Otherwise, the event will be deleted from the Championship Calendar. The official calendar will be available at the CEZ ASN offices and at www.cez-motorsport.com.

1.2 Regulations/Officials

All Zone Championships must be organised in conformity with the specifications listed in the International Sporting Code and its Appendices, the national Sporting Codes of the ASN's where the events will be organised, the present regulations for the FIA Central European Zone Championships and the supplementary regulations of the event concerned.

The Officials are appointed by the ASN of the organiser; at least one of the Stewards should be nominated from one of the other CEZ ASNs (with exception of Slalom and Drifting events, where only one Steward is obligatory). In order to support foreign competitors a Crews' Relations Officer speaking English language should be appointed in the Supplementary Regulations.

1.3 Supplementary Regulations

The regulations should be published in English, plus the national language where appropriate. Copies of the definitive regulations must be sent by email (automobily@autoklub.cz) to the secretariat of the Zone at least 45 days before the event is due to start to be published at www.cez-motorsport.com.

If an organiser is not able to run all classes, groups, categories published in the Zone Championship regulations at his event, he must clearly state such restriction in the S.R. Also the minimum number of entries for the classes, groups, categories - if there is one - for the events must be stated in the S.R.

1.4 List of seeded Drivers

The entries of drivers listed on 1st, 2nd or 3rd place on a national priority list, must not be rejected.

1.5 Entries

Only drivers or first drivers of crew who are holders of national or international licences of one of the ASNs of the countries of the Zone may enter. For the Championship - results only drivers with a minimum age of 16 years will be respected (different age limits for the participants in the Autocross JuniorBuggy Championship and the Karting Championship are defined in the Championship rules for these disciplines). If drivers younger than 16 years are allowed to participate in events according national rules, this will be stated in the S.R. of such events – but these drivers will not be respected for the Championship-results.

Entries should be submitted to the organiser of the event concerned according to the prescriptions of the FIA International Sporting Regulations. The Zone Countries are free to make mutual agreements concerning entry fees.

For all entries to CEZ Championship events the following applies:

The classification of participants in CEZ Zone events for the Zone Championships must neither depend on any additional entries nor additional entry fees. An entrant/driver sending the entry form to an organiser or ASN agrees to take part in this event even if he has not paid the entry fee in time. An entrant/ driver not presenting him at the verification of the event and not excusing this in written form in advance will have to pay the entry fee.

1.6 Attribution of Points and Classification

In each discipline, group, division or category of the Zone Championships, points are awarded in accordance to the scale published in the regulations, chapters "Classifications" for every Championship. All results will be counted; no results will be retained from the final list (for Karting see Art. 8.4).

Only those drivers, who have taken part in at least one event in the respective discipline under the sovereignty of another ASN than their parent one, will be classified for the final results of the CEZ Championship. „Taking part“ means to be at the start of at least one race (heat) of the event in question (for Autocross and Rallycross this means to participate in the official practice).

Further regulations see rules for each Zone Championship.

Should there be less than 3 drivers classified in the final result of a group or a category of CEZ Championship, this Championship will be declared null and void.

1.7 Dead heat (ex aequo)

For the drivers whose total of points is identical, the rule deciding will give consideration to:

- 1) the value of the places (1st place, 2nd place, 3rd place, etc.) obtained in the main classification of the qualifying events taken into account for the granting of their points.
- 2) the value of the places obtained in the classifications of the qualifying events in which every one of them has participated.

In cases of a further tie, the drivers will be listed in the Championship-result on the same position.

1.8 Results

The ASNs have to take responsibility, that the organisers will send the official results and corrected entry lists of the events, according the classes and classifications of the resp. CEZ Championship, a.s.a.p. to the sporting secretary of the zone (email: kopecky@autoklub.cz), where the Championship-results will be set up according these official documents. The unofficial results of the Zone Championships will then be published during the year on the website www.cez-motorsport.com. If there are no objections against brought forward by email/fax/letter from the ASN of the competitor/drivers concerned, the Championship-results will be declared as "final and official" from 12th November 2025.

1.9 Prizes

- a) CEZ Championships: In every discipline of the Zone Championship the first placed drivers and co-drivers in the groups or categories or divisions determined in the regulations of this discipline are awarded.
- b) Nations Trophy: At the end of the season the numbers of 1st placed drivers of the Championship results of the various disciplines will be added for a Nations Trophy (as for Olympic rankings). For every country the places of its licence holders will be respected.
The country with the highest number of 1st placed drivers will be declared winner of the Nations Trophy of the respectively year. In case of ties the higher number of 2nd placed drivers and following the higher number of 3rd placed drivers will decide. The representatives of the ASNs placed 1st, 2nd and 3rd will be presented at the yearly prize-giving ceremony of the Central European Zone.
- c) Ladies Cup: The women scoring the most points in their specific disciplines (respecting all classes, groups, categories together) are presented at the CEZ Prize Giving that year.
- d) Prize-giving: The annual ceremony will be held in a country designated by the board of the CEZ countries and will be organized with the financial participation of all members of the zone. The fee will be specified by the board of the CEZ countries.

1.10 Administration

The CEZ-Championship is administered by the Czech ASN (A.C.C.R., www.cez-motorsport.com)). Communications by the entrants/drivers should be done via their parent ASN's.

1.11 Award for "Talent of the year"

The Board of the CEZ countries may decide every year to award extraordinary performance of young drivers from the CEZ countries by the title "Talent of the year". The awarded drivers (max. 2 drivers per year) shall show the outcome of talents from the Central European Zone into the international FIA sporting scene.

The following conditions must be respected:

- Maximum age of the driver(s): 25th birthday reached during the year in question.
- The driver(s) will be awarded for the results gained at the following events: FIA-Championships, FIA Cups, FIA series, international series approved by the FIA.

The ASNs must send the applications for their candidates until 30th October of the calendar year in which these drivers reached their successes to the office of CEZ President and following the proposal for the awards, these will be circulated to all ASNs for approval.

The Talent(s) of the year will be presented at the prize-giving ceremony of the Central European Zone.

Art. 2. SAFETY PRESCRIPTIONS

See valid FIA respectively CIK/FIA regulations.

The use of a FHR (HANS®) System is obligatory for all discipline except Historic cars (not valid for FIA classes only, where FHR is obligatory), Rallycross (STC), Autocross (national cars), slalom, karting, Cross Country (SSV) and drifting where is strongly recommended to all participants in CEZ events.

Art. 3. 2025 FIA CENTRAL EUROPEAN ZONE RALLY CHAMPIONSHIP

3.1 Eligible Cars

- CEZ1 – Rally2 and R5 cars
- CEZ2 - 4WD cars (except Rally2 and R5) + RGT cars + 2WD over 2000 cc
All cars with FIA homologations (including expired one) or ASN homologations
- CEZ3 - 2WD cars
 - FIA homologated cars classes RC4 and RC5
 - FIA homologated cars expired one or ASN homologated cars with following cylinder capacity:
 - petrol engine - corrected cylinder capacity up to 2000 cc
 - diesel engine - nominal cylinder capacity up to 2000 cc

3.2 Events counting towards the Championship

Venues and dates according the FIA CEZ Championship Calendar; see www.cez-motorsport.com).
Should the number of qualifying rallies organised finally be less than three, the Championship would be considered as not having taken place.

3.3 Organisation of the events

The events are to be organised according to the FIA-Sporting Code and its Appendices.

3.4 Classification

Points will be awarded, to the principal drivers correctly entered or designated as such, according to the scale:

25 - 18 - 15 - 12 - 10 - 8 - 6 - 4 - 2 - 1, in each of the groups mentioned in Art. 3.1.

The following drivers will be declared winners of the Central European Zone Rally Championship at the end of the year:

- The drivers (driver and co-driver) having scored the most points in CEZ1
- The drivers (driver and co-driver) having scored the most points in CEZ2
- The drivers (driver and co-driver) having scored the most points in CEZ3

Art. 4. 2025 FIA CENTRAL EUROPEAN ZONE HILL CLIMB CHAMPIONSHIP

4.1 Eligible Cars

Each Competition is open to cars holding a national technical passport and complying with the Appendix J, except the cars in Group 4 and Group 5, where a series fuel tank with its original location and refuelling is allowed, for the following categories and groups:

4.1.1 Category 1

Group 1	Pf 15 to 39
Group 2	Pf 40 to 79
Group 3	Pf 80 to 119
Group 4	Pf 120 to 159
Group 5	Pf >159

4.1.2 Category 2

The cars will be classified in the following groups on the base of the Pf value:

Group P1 (Proto 1)	Pf 50 to 59
Group P2 (Proto 2)	Pf 60 to 89
Group P3 (Proto 3)	Pf 90 to 109
Group P4 (Proto 4)	Pf > 110

4.3 Organisation of the events

The events are to be organised according to the FIA Sporting Code and its Appendices. The minimum length of the race will be 5 km, which can be performed in one, two or three heats.

4.4 Classification

At the end of each qualifying event a general classification for each Division mentioned in Art. 4.1 will be established. For each Division points will be allocated as follows:

25 - 18 - 15 - 12 - 10 - 8 - 6 - 4 - 2 - 1.

If there are less than 5 starters ½ points will be allocated.

As a driver is allowed to participate only with one car in one event, the points of drivers starting with different cars in the different events will be cumulated for the final results of the Championship.

The following drivers will be declared winners of the Central European Zone Hill Climb Championship at the end of the year:

- The driver having scored the most points in Group 1
- The driver having scored the most points in Group 2
- The driver having scored the most points in Group 3
- The driver having scored the most points in Group 4
- The driver having scored the most points in Group 5
- The driver having scored the most points in Group P1
- The driver having scored the most points in Group P2
- The driver having scored the most points in Group P3
- The driver having scored the most points in Group P4

Art. 5. 2025 FIA CENTRAL EUROPEAN ZONE CIRCUIT RACING CHAMPIONSHIP AND ENDURANCE CHAMPIONSHIP

5.1 Eligible Cars

The Championship is reserved for:

DIVISION 2

Eligible groups:

- **D2 E2-2.0**
- **D2 F3**
- **E2-SS-2000 cc** (E2-2.0 / Formula Open)
 - All formula 3 cars that do not comply with the FIA CEZ regulations for class Formula 3
 - Formula cars according to the Art. 277 of FIA App. J
 - Formula Master
 - Formula Renault
- **Formula 3 cars:**
 - according to the Art. 275 of applicable (period specific) FIA App. J with safety equipment according to 2019 App. J
 - Formula 3 cars of 2014, 2015, 2016, 2017 and 2018 correspond with the FIA F3 Regulation.
 - Permissible engines:
 - All Formula 3 engines with a maximum air intake of up to 26 mm, which are homologated by the FIA or FIA homologated.
 - Opel OPC (from the ATS Formula 3 Cup with a maximum air intake up to 27mm)
 - Fiat FPT Regulations 2012, Italian F3 Championship 2012 with a maximum air intake up to 31 mm.
 - Toyota engine 3S-GE-SXE10 according to the regulations of the Euro Formula Open for 2012 – 2018 with a maximum air intake up to 31 mm.
 - NBE Mugen Honda National Class with a maximum air intake up to 26.3 mm.
 - Formula Regional Tatuus F3 T318 with Alfa Romeo engine or Renault engine.
- **Minimum weight:**
 - For the Formula 3 category of vehicles up to and including year of construction 2011, the weight of the vehicle with driver wearing his full racing clothing and safety equipment shall not be less than 540 kg at any time of the event.
 - Formula 3 vehicles of the years of construction 2012 – 2018 (with rider wearing his full racing clothing and safety equipment, at any time of the event, not less than 550 kg).
 - Formula 3 vehicles up to and including year of construction 2011 with Toyota engine 3S-GE-SXE 10(with rider wearing his full racing clothing and safety equipment, at any time of the event, not less than 580 kg).
 - Dallara F320 vehicles, (with driver wearing his full racing clothing and safety equipment, at any time of the event, not less than 580 kg).
 - Formula Renault 2.0 the lower weight of a Formula Renault 2.0 vehicle, no matter which models 2000 to 2009, including driver with his full driver and safety equipment may not be less than 570 kg at any time of the event.
 - Racing weight: The minimum race weight in a Formula Renault 2.0, model 2010 may not be less than 580 kg including driver including his equipment.
 - The minimum track weight of a Formula Renault 2.0, model 2013 must not be less than 580 kg including the driver and his equipment.
 - Tatuus F3 T318 with driver wearing his full racing clothing and safety equipment, at any time of the event, not less than 675 kg).
- **Total vehicle height for E2-2.0 and F3 cars:**
 - With the exception of the rollover device, no part of the vehicle shall exceed 960 mm the ground with driver on board. However, parts of the roll-over device which are higher than 930 mm above the ground, should not be designed in such a way that they have an aerodynamic influence on the race car.

DIVISION 4

Eligible groups:

- **D4 TC** class TCR, class TCL5, class TCL4
- **D4 GT** class GT3, class GTC, class GT4
- **D4 TCC** class TCC2, class TCC4, class TCC5

Eligible cars:

- **TCR** according to TCR Eastern Europe regulations and BOP compliance
- **GT3** according to GT3 regulations, see FIA App. J Art. 257, and applicable homologation form and BOP compliance with data recorder
- **GTC** according to applicable GTC regulations and BOP compliance
- **GT4** according to applicable GT4 regulations and ASN homologation form
- **TCC2** Renault Clio Cup V incl. facelift 2024 cars according to cup regulations
- **TCC4** Renault Twingo Cup cars according to cup regulations
- **TCC5** Mazda MX 5 Cup cars according to cup regulations

➤ **Minimum weight**

Minimum weight = weight of the car incl. operating fluids, without fuel (allowed fuel volume for mandatory checks is max. 3 l), without driver and his safety equipment. The car must comply with the minimum weight according to applicable regulations or according to the BOP value specified by CEZ Working Group at the time of scrutineering, at all times during the race and within Parc Fermé time.

➤ **BOP**

The CEZ Working Group reserves the right for all groups of D4 division to immediately introduce or change respected BOP (minimum weight, intake restrictor diameter, turbocharger pressure).

BOP for CEZ events:

- a) All GT3, GT4 and TCR cars must respect the latest issued CEZ BOP regulations.
All GT3, GT4 and TCR cars must be equipped with scrutineering data recorder. For scrutineering purposes, it will be required that all GT3, GT4 and TCR cars reproduce their dataset recordings for all official sessions. The data should be given through dedicated USB stick/SD card (one per car). All data should be provided at the end of each session during the whole Parc Fermé time for the qualifying and the race **with assistance of a Chief Scrutineer**. Failing to deliver data in time or bad quality of datasets may result into sporting penalties.
- b) **GTC cars:**
GTC cars must respect BOP (minimum weight, intake restrictor diameter, turbocharger pressure) according to their current Cup regulations or 2024 Cup regulations, for the first race of 2025 season.

Specific regulations:

1. **Class GTC**

Class GTC cars according the officially published / submitted technical regulations of Porsche Cup, Ferrari-Challenge, Lamborghini Super Trofeo, Ginetta Cup and any further series, all together. The only exceptions of the Cup's technical regulations for GTC-cars are the brakes (which are free).

For the formation of a one-off GTC class they are more than six identical cup vehicles necessary to strictly comply with the relevant technical regulations of the cup

2. **Class GT3**

Fire extinguishers for GT3 cars: All cars must be equipped with an extinguishing system. The system must be used in accordance with the manufacturer's instructions and with Technical Lists n° 16 or 52, and in accordance with Article 253-7.2 with an exception of the means of triggering.

3. **Separate race**

If there are more than 16 cars of one class entered to the race, the organizer could organize a separate race.

4. New class

For the formation of a new class, they are more than six vehicles necessary to strictly comply with the relevant technical regulations of class.

Additional regulations for division D4:

All D4 cars must be equipped with two headlights, two red stop lights, two rear red lights, rain light and rear sidelights. All lighting equipment must be in working order throughout the competition. For safety reasons, it is obligatory for headlights to produce white or yellow beam.

For all D4 cars is recommended to be equipped with catalytic convertor.

DIVISION 5

Eligible cars:

- **CN** up to 3000 ccm
- **CN2** according to FIA regulations – max. engine capacity 1620 ccm, turbo
- **Radical Cars** according to the ERC 2013 up to 3500 cc including SR8
- **E2-SC** up to 3000 cc
- **Supersport KTM X-Bow, KTM – X Bow**
- **Praga R1** with max. diameter of restrictor 41 mm - according to Praga R national technical regulations
- **SCC** according to regulations for SCC (max. capacity up to 5000 cc, stock engine, sealing...)
- **LMP3** according to tech. regulations of ACO/Automobile Club de l'Ouest
- **LMP2** according to tech. regulations of ACO/Automobile Club de l'Ouest before 01/01/2017 or with engine Gibson GK-348 (small engine).

Additional regulations for division D5:

All D5 cars must be equipped with two headlights, two red stop lights, two rear red lights, rain light and rear sidelights. All lighting equipment must be in working order throughout the competition. For safety reasons, it is obligatory for headlights to produce a white or yellow beam.

For all D5 cars is recommended to be equipped with catalytic convertor.

* = according to the national regulations (for each car a confirmation of the domestic ASN must be shown that the car complies with the national regulations) and according to the following rules:

- If the car starts in accordance to the Cup regulations, the competitor must present the relevant technical regulations on any request of the scrutineer.
- If there are more than 10 D5 cars entered to the race, the organizer could organize a separate race.

For all cars:

Competitors are responsible to show at any time during the events the technical regulations according which their car was built.

Additional regulations for all divisions:

For all events, for all classes is set following noise limit value: 110dB (0,5 m measuring method)

Unless otherwise defined in the Supplementary Regulations of a specific race.

5.2 Events counting towards the Championship

Venues and dates according the FIA-CEZ Championship Calendar (see www.cez-motorsport.com). Should the number of qualifying events organised finally be less than three, the trophy would be considered as not having taken place.

Every driver with a valid licence from the CEZ Zone countries that starts in the FIA CEZ Trophy race will automatically be classified in the respective group or class where his car is assigned as per CEZ rules in the results of the specific race.

5.3 Organisation of the events

Due to the FIA CEZ can start only at the circuit with FIA homologation.

Organiser with Stewards will make a decision about a group of the cars how they will start together.

Organiser has to inform drivers about a detail of the insurance policy in Supplementary regulations. Insurance must cover all damages on the track, officials, marshals and spectators. A fee of the insurance could be included in the Entry Fee or information has to be done together with an Entry fee. Insurance must be valid for the whole racing weekend.

The organizer is strictly recommended to organize the event for the CEZ-Championship in two days.

On Friday there must be the free practice (25 min.) for each group of minimum 15 participants and from 12 a.m. the administrative checks and scrutineering. The entry fee is to the organizer's discretion, but

for Junior drivers (drivers that are aged 21 years or younger in the current season) is fixed to 50 % of the entry fee of each event.

There will be rolling starts for D4GT and D5 and standing starts for D2, D4TC and D4 TCC.

If the Division 4 and Division 5 are racing together, their start grid has to be separated. Stewards decide which grid will be placed in front.

If the TCC Classes racing together with other Classes, their start grid has to be separated. Stewards decide which grid will be placed in front.

5.3a Organisation of the sprint race

The number of cars allowed to take part in Qualifying and to start the race is as provided for in supplement N. 2 of Appendix O to the Code.

A qualifying session of at least 20 minutes must be organised for every sprint race of D2, D4 GT, D5.

A qualifying session of at least 20 minutes must be organised for both sprint races D4 TC and D4 TCC.

The duration of the race shall be 25 minutes minimum.

No race should be started later than 3:30 p.m. on Sunday to be respected for the CEZ-Championship.

If technical means are used by the marshals to remove the car to a safe position, this assistance cannot be used to help the driver/car concerned to re-join the race.

5.3b Organisation of the endurance race

The number of cars eligible for practice shall depend on the licence of the circuit on which the event is taking place. A qualifying session of 30 minutes must be organised.

An Endurance race shall be run 60 minutes + 1 lap duration. The races should be run on Saturday evening latest to be respected for the CEZ-Championship.

It will be compulsory, in each race, to carry out an obligatory pit stop and change of driver in 2 driver's crew.

Obligatory pit stops must begin between the 25th and the 35th minute (not before 25 min 00 seconds 000 and not after 34 minutes 59 seconds .999) of the race. This period will be indicated by showing a board PIT STOP. The minimum duration of the obligatory pit-stop must be 120 sec. If this pit-stop is shorter, the missing time will be tripled and automatically added to the racing time.

A pit stop shall be deemed to have begun upon crossing the line which marks the beginning of pit lane timekeeping.

Exceptionally slow driving or stopping in the fast lane shall be prohibited.

In case of 2 drivers crew driver change must be done only during this obligatory pit stop.

The mandatory Pit Stop shall be carried out in the inner lane.

The obligatory pit stop cannot be carried out when the safety car is deployed or when the race is suspended.

In this case it will be decision of the Clerk of the Course to extend "window" for the obligatory pit stop.

This extension will last 5 minutes or 10 minutes. This extension will be communicated via the timing screens or by means of a display board.

During the Pit Stop:

1. The engine must be switched off, in case of any technical intervention, except cleaning the windscreen and cooling openings.
2. In case of 2 drivers these crew drivers must change.
3. All other operations are only permitted after point 2 above was carried out.
4. For all permitted operations, the maximum number of mechanics/persons to operate shall be FOUR (4). At any time, these people will be recognized by wearing a vest (those team/mechanic vests will be provided by the promoter). Teams may have an additional person (Team Manager), who will not be included in the maximum number of 4 mechanics; the exclusive task of this person will be to stop the car before the assigned box and let it go once the operations have finished.

All mechanics/persons must wear an work clothing.

Permitted Operations:

1. Change of driver
2. Tyres compression adjustment / change tyres forbidden, only puncture
3. Cleaning the windscreen and cooling penning's.
4. The adding of oil, water or brake fluid is authorized as well as the brake circuit draining.
5. Small mechanic operations for safety reasons (i.e. fix a fallen bumper, etc.) are authorized.
6. In case of necessity, it is allowed to start the car with an external battery.

All these operations cannot be carried out during the refuelling operation.

- a) The refuelling of cars with refuelling tower is forbidden.

b) Refuelling is only allowed in the special refuelling area and will be carried out by three team members using cans with max. 25 litres capacity or a rotating system manually operated with max. 60 litres capacity. Refuelling in the pit line in front of the pit garages is allowed only for the teams using manual refuelling pit stop system (with max. 60 litres capacity) approved by scrutineers before an event.

A team member must be ready with a fire extinguisher of at least 6 kg capacity. On refuelling, the competitor must ensure, that the car was electrically grounded before and during the refuelling procedure, that the car is standing on its complete wheels, that the engine is switched off, that the safety belts of the driver, if remaining in the car, were released, that no works were done on the cars.

ALL THESE TEAM MEMBERS MUST WEAR COMPLETELY FLAME PROOF EQUIPEMENT (OVERALLS, GLOVES, BALACLAVAS AND HELMETS).

Work on the car is allowed only in the box or designated working area in the pit lane. The engine of the car must be switched off.

5.4 Driving

If the best qualifying time of a driver/team exceeds 120% of the fastest time in the group or classes, if participating, they may not be allowed to take part in the warm up and the race. Under exceptional circumstances the Stewards may permit the car to start the warm up and race. All qualified drivers must have a place in the race.

Only cars which have covered at least 70 % of the distance covered by the winner of the concerned group or classes will be classified.

5.5 Penalty

The Stewards may impose any penalty according to the ISC.

The maximal cash penalty is fixed to 1000 EUR.

The penalty "Drive Through" during the last 10 minutes of an Endurance Race and during the last five minutes of a sprint race is fixed to 30 second time penalty, which shall be added to the driver's time concerned.

5.6 Scrutineering

Each ASN has a right to provide 1 scrutineer for CEZ Championship. If such is provided, this official is fully responsible for all the scrutineering of the cars with the homologation issued from his country.

5.7 Observer

The CEZ Working Group provides 1 observer (second steward, no from hosting ASN) and CEZ Technical Delegate, who is responsible for the running of the event in accordance to these regulations and is responsible for the control of the results. The observer prepares a detailed report of each event, send to every chairman of the Working Group within FIA CEZ.

5.8 Price giving ceremony

The price giving must take place on the podium immediately after each race and. The ceremony is only for FIA CEZ drivers and for the drivers of National Championship as well as the group of the event organizer

Price giving for the groups and classes:

- 1 - 4 starters: trophy for the winner
- 5 and more starters: trophy for the first 3 drivers

5.9 Classification

A maximum of 2 heats per event in sprint and only one heat per event in endurance will be taken into consideration for classification of the Zone-Championship (number of heats listed in the CEZ Championship-Calendar). Points for the title will be awarded for each heat in General classification and each group of Division 2, in each class of group D4 TC, in General classification and each class of group D4 GT and each class of group D4 TCC, in group Division 5 according to the following scale:

25 - 18 - 15 - 12 - 10 - 8 - 6 - 4 - 2 - 1

Note:

- In order to acquire the full amount of points the race must last at least 70% of the indicated min. length
- If the race lasts 50% to 70% of the indicated minimum length, ½ of the points shall be awarded
- If the race lasts less than 50% of the indicated minimum length no points shall be granted
- To qualify for 50% of points up to 5 starters must appear in the group or class
- To qualify for 100% of points a minimum of 6 starters must appear in the group or class

The following drivers will be declared winners of the Central European Zone Circuit Championship and Central European Zone Endurance Championship at the end of the year:

- The driver having scored the most points of all class results of D4 TC
- The driver having scored the most points of group D4 GT
- The driver having scored the most points in class GT3
- The driver having scored the most points of all class results of D4 TCC
- The driver having scored the most points in class TCC1 (if will be no winner of D4 TCC)
- The driver having scored the most points in class TCC4 (if will be no winner of D4 TCC)
- The driver having scored the most points in Group D5
- The driver having scored the most points in Division 2
- The driver having scored the most points in Group Formula 3 in sprint race

Should there be less than 10 drivers classified in the final result of a group or a category of CEZ-Championship, this Championship will be declared null and void.

FIA CEZ Technical Regulations for D2 Formula Racing Cars

Any change not expressly permitted in these regulations is prohibited!

Class Formula 3

Class E2-2000

Approved vehicles / chassis:

Formula vehicles up to and including year of construction 2018 F3 and Dallara 320

These vehicles (models) must comply with the FIA Technical Regulations, Annex J of the ISG Article 275 (Formula 3 to 2018) or Article 277 (Formula Free). Exceptions: Vehicle weight and vehicle height, this is regulated in this regulation. Updates are allowed.

The vehicles are divided into the following categories:

Class: Formula 3

Formula 3 vehicles with the following engines:

- All Formula 3 engines with a maximum air intake of up to 26 mm, which are homologated by the FIA or FIA homologated.
- Opel OPC (from the ATS Formula 3 Cup with a maximum air intake up to 27mm)
- Fiat FPT Regulations 2012, Italian F3 Championship 2012 with a maximum air intake up to 31 mm.
- Toyota engine 3S-GE-SXE10 according to the regulations of the Euro Formula Open for 2012 – 2018 with a maximum air intake up to 31 mm.
- NBE Mugen Honda National Class with a maximum air intake up to 26.3 mm.
- Formula Regional Tatuus F3 T318 with Alfa Romeo engine or Renault engine.

Class: E2-2000

Formula vehicles with the following engines:

- VW A 34 engine with 34 mm air intake
- FIA Homologated F3 engine with max. 28 mm air intake from FIA F3
- VW Power Engine
- Formula Master
- Formula Renault vehicles built from 2000 to 2018. For these Formula Renault 2.0 vehicles, the technical regulations of the NEC of the respective year of construction apply. Updates are allowed.

Weight of each class:

To determine the weight, the official scale of the race organiser must be recognized. No protest is allowed against this scale. Each participant has the opportunity to weigh his vehicle on this scale and adjust the weight if necessary.

Minimum weight:

- For the Formula 3 category of vehicles up to and including year of construction 2011, the weight of the vehicle with driver wearing his full racing clothing and safety equipment shall not be less than 540 kg at any time of the event.
- Formula 3 vehicles of the years of construction 2012 – 2018 (with driver wearing his full racing clothing and safety equipment, at any time of the event, not less than 550 kg).
- Formula 3 vehicles up to and including year of construction 2011 with Toyota engine 3S-GE-SXE 10 (with driver wearing his full racing clothing and safety equipment, at any time of the event, not less than 580 kg).
- Dallara F320 vehicles (with driver wearing his full racing clothing and safety equipment, at any time of the event, not less than 580 kg).
- Formula Renault 2.0 the lower weight of a Formula Renault 2.0 vehicle, no matter which models 2000 to 2009, including driver with his full driver and safety equipment may not be less than 570 kg at any time of the event.
- Racing weight: The minimum race weight in a Formula Renault 2.0, model 2010 may not be less than 580 kg including driver including his equipment.
- The minimum track weight of a Formula Renault 2.0, model 2013 must not be less than 580 kg including the driver and his equipment.
- Tatuus F3 T318 with driver wearing his full racing clothing and safety equipment, at any time of the event, not less than 675 kg).

Total vehicle height for Formula 3, and E2-2000 vehicles:

With the exception of the rollover device, no part of the vehicle shall exceed **960 mm** the ground with driver on board. However, parts of the roll-over device which are higher than **930 mm** above the ground, should not be designed in such a way that they have an aerodynamic influence on the race car.

Art. 6. 2025 FIA CENTRAL EUROPEAN ZONE AUTOCROSS CHAMPIONSHIP

6.1 Eligible Cars

All cars according the actual FIA App. J 279A resp. with some changes acc. national regulations (each of these cars must be accompanied by a confirmation of the home ASN that the car corresponds with the national regulations).

Diesel-engine is not allowed.

The Championship is reserved for:

- SuperBuggy (over 1600 cc up to 4000 cc)
- Buggy1600 (up to 1600 cc)
- Junior Buggy up to 600 cc
age of the drivers: 13 – 21 years (during the Calendar year, in any case the driver who reaches the maximum age is allowed to finish the Championship).
 - The weight of buggies:

The weight of the vehicle, without the driver on board wearing his/her full racing apparel, with the fluids remaining at the moment at which the measurement is taken, must at all times during the competition comply with the following scale of minimum weights according to the cylinder capacity, the number of cylinders, the type of engine and the type of transmission:

Cylinder Capacity	2WD		4WD-4cyl norm.asp.		4WD-6cyl + 4WD-4cyl superch.		4WD-8cyl and over + 4WD-6cyl superch.	
		with driver		with driver		with driver		with driver
600 cm ³	405 kg	470 kg	460 kg	525 kg	-	-	-	-
1300 cm ³	460 kg	545 kg	515 kg	600 kg	575 kg	660 kg	625 kg	710 kg
1600 cm ³	490 kg	575 kg	545 kg	630 kg	595 kg	680 kg	645 kg	730 kg
2000 cm ³	540 kg	625 kg	595 kg	680 kg	645 kg	730 kg	695 kg	780 kg
2500 cm ³	590 kg	675 kg	645 kg	730 kg	695 kg	780 kg	745 kg	830 kg
3000 cm ³	615 kg	700 kg	670 kg	755 kg	720 kg	805 kg	770 kg	855 kg
3500 cm ³	640 kg	725 kg	695 kg	780 kg	745 kg	830 kg	795 kg	880 kg
4000 cm ³	665 kg	750 kg	720 kg	805 kg	770 kg	855 kg	820 kg	905 kg

- TouringAutocross
TouringAutocross and Group H, passed homologation car, or according CEZ Rallycross Championship regulations, Art. 7.1/SuperCars (Additionally cars with expired homologation).
General: max. cylinder capacity up to 5.000 cc; all safety equipment has to be according valid FIA rules; all cars must be equipped with catalytic converter; noise-limit 100 dB.
- TouringAutocross1600
TouringAutocross and Group H according the national regulations with the following exceptions: only two-wheel-drive cars up to 1600 cc (atmospheric engine only); catalytic converter is free; noise limit 100 dB; safety devices must conform to actual FIA standards (except: fuel-tank: original one, or tank made of alloy with a max. capacity of 20 litres or homologated Motorsport-tank with homologations expired [plus 4 years]; seats and safety-belts: homologation expired [plus 5 years]).
Announcement for year 2026 onwards: all safety equipment has to be according valid FIA rules.
 - The weight of Touring cars:

The minimum weight of the vehicle, without the driver on board wearing his/her full racing apparel, and with the fluids remaining at the moment at which the measurement is taken, must at all times during the competition comply with following scale of minimum weights according to the cylinder capacity:

		with driver
Up to 1000 cm ³	695 kg	780 kg
Over 1000 cm ³ and up to 1400 cm ³	785 kg	870 kg
Over 1400 cm ³ and up to 1600 cm ³	875 kg	960 kg
Over 1600 cm ³ and up to 2000 cm ³	955 kg	1040 kg
Over 2000 cm ³ and up to 2500 cm ³	1055 kg	1140 kg
Over 2500 cm ³ and up to 3000 cm ³	1135 kg	1220 kg
Over 3000 cm ³ and up to 3500 cm ³	1225 kg	1310 kg
Over 3500 cm ³ and up to 4000 cm ³	1300 kg	1385 kg
Over 4000 cm ³ and up to 5000 cm ³	1400 kg	1485 kg

➤ CrossCars according Art. 279B of FIA ISC Appendix J or cars with a roll cage which has ASN Certificate (homologation). A cubic capacity of an engine must be following:

- - 4-cylinders engine max. 600 cc
- - 3-cylinders engine max. 890 cc

For all buggies homologated seats, FT3 tanks and a leak-proof, non-inflammable bulkhead by this tank are recommended.

Drivers must to be equipped by safety overall with FIA Hologram label.

6.2 Competition counting towards the Championship

Venues and dates according the FIA CEZ Championship Calendar; see www.cez-motorsport.com).

Should the number of qualifying competitions organised finally be less than three, the Championship will be considered as not having taken place.

At least one of the Stewards must be nominated from one of the other CEZ ASNs. All decisions have to be issue in English by FIA format.

6.3 Organisation of the competition

The competitions are to be organised according to the FIA Sporting Code and its Appendices, the 2025 SPORTING REGULATIONS OF THE FIA EUROPEAN AUTOCROSS CHAMPIONSHIP except of Art. 1, 2, 3.2, 4, 5.1, 5.2, 5.3.3, 5.3.4, 6, 7, 8, 9, 10.3 -10.7, 11.1.1, 11.3.2 a), b), 12.1.7 - 8, 13.1.2, 14.1, 14.2 (evidence of reprimands), 14.3, 15.1.2, 15.1.3, 15.2, 15.3.

At least one of the Stewards must be nominated from one of the other CEZ ASNs. The foreign Steward must send the results and all the important documents to the secretariat of the CEZ till 48 hours by e-mail.

All Forms of a Briefing have to be in English (or translated to the English).

6.4 Classification

In each of the five divisions, mentioned in Art. 6.1, points will be awarded in accordance with the SPORTING REGULATIONS OF THE FIA 2024 EUROPEAN AUTOCROSS CHAMPIONSHIP

The following drivers will be declared winners of the Central European Zone Autocross Championship at the end of the year:

- The driver having scored the most points of TouringAutocross and Group H
- The driver having scored the most points of TouringAutocross 1600
- The driver having scored the most points of Buggy1600
- The driver having scored the most points of SuperBuggy
- The driver having scored the most points of Junior Buggy
- The driver having scored the most points of CrossCars

Art. 7. 2025 FIA CENTRAL EUROPEAN ZONE RALLYCROSS CHAMPIONSHIP

7.1 Eligible Cars

For all Divisions and classes (if not otherwise defined in the resp. Div./class) is valid:

- Drivers-equipment according valid FIA-Homologations (except SuperTouringCars).
- Cut slick-tyres according definition of FIA App. "J" 2015, Art. 9.2 are allowed.
- The use of a FHR System is mandatory to all participants for SuperCars and Super1600 - for SuperTouringCars (STC) it is strongly recommended and from year 2026 mandatory.
- Fire extinguisher systems are recommended.
- Diesel-engine is not allowed.

SuperCars: 4WD-cars up to 3.500 cc or 2WD-cars (no limits of cubic capacity), conforming to the FIA RX regulations 2020 (SuperCars conforming to the FIA RX regulations 2012 until 2019 are allowed); R5, Super-Lite

Min. weights (incl. driver and equipment) according FIA App. "J", Art.279.

+1600-2000 cc = 1.100 kg;

+2000-2500 cc = 1.130 kg;

+2500-3000 cc = 1.210 kg;

+3000-3500 cc = 1.300 kg;

+3500 cc = 1.380 kg.

Additionally, cars with expired homologation from actually SuperTouringCars, 4WD, up to 4000 cc, are eligible or 2WD cars (no limits of cubic capacity), are eligible.

To make sure, that cars from SuperTouringCars can compete with the modern ones, the following exceptions are defined:

- Air-restrictor and safety-equipment according valid FIA rules; dashboard free; cars must be equipped with catalytic converter; noise-limit 100 dB.
- Min. weights (incl. driver and equipment): see above.

Super1600: According valid FIA-rules 2014 to 2021 (The cars must be homologated in the Year 2010 or later acc. FIA).

SuperTouringCars (Group H): All cars must correspond with 2025 CEZ Technical regulations for STC. See Appendix 1 RX

Drivers must to be equipped by safety overall with FIA Hologram label.

7.2 Competition Numbers

On the lower part of the left and right rear side windows of the car, the national flag of the driver and the driver's surname will displayed between 6 cm and 10 cm high. The two numbers for each rear side window shall be 20 cm high with a stroke width of 40 mm, coloured fluorescent orange (PMS 804). At the top Right side (looking from inside the car) of the front window there shall be a fluorescent orange (PMS 804) competition number (14 cm high) on a clear background. One matt white roof panel (35 cm wide by 35 cm high), must be placed on the roof with the top towards the front of the car. A matt black competition number, 5 cm wide by 28 cm high, will be displayed on this panel,

Competition numbers will be allocated as follows:

Supercars:	1 to 99	Super1600:	101 to 199
SuperTouringcars-2000:	201 to 299	SuperTouringCars-1600:	301 to 399
SuperTouringCars+2000:	401 to 499		

7.3 Competitions counting towards the Championship

Venues and dates according the FIA CEZ Championship Calendar; see www.cez-motorsport.com.

Should the number of qualifying competitions organised finally be less than three, the Championship would be considered as not having taken place.

At least one of the Stewards must be nominated from one of the other CEZ ASNs. All decisions have to be issue in English by FIA format.

The foreign Steward must send the results and all the important documents to the secretariat of the CEZ till 48 hours by e-mail.

7.4 Organisation of the competitions

The competitions are to be organised according to the FIA-Sporting Code and its Appendices. In case of a common race the organiser must ensure a separate classification for each division.

The competitions will be run according the FIA Sporting Code and its Appendices and 2023 SPORTING REGULATIONS OF FIA EUROPEAN RALLYCROSS CHAMPIONSHIP except of Art. 1, 2, 3, 4, 5.3, 6, 8, 9, 10, 11, 13.3-13.5, 14.4 (CLO), 15.2c (first corner), 17.1 (point 23), 17.4, 19, 20, 21.

All Forms of a Briefing has to be in English (or translated to the English).

Additionally:

If a competitor wishes to participate within a Division where he is already classified with a replacement car with a lower engine capacity, he has to respect the weight of the relevant class of this Division.

A Joker Lap and a starting grid situated outside the track are recommended.

There will be 3 or 4 Heats at each competition.

Number of the cars on the grid for less than 11 cars:

Number of the cars	Q1	Q2
10	5	5
9	4	5
8	4	4
7	3	4
6	3	3

To be classified the driver must finish in minimum 1 Heat, reaching the same number of laps as the winner of this Heat and he must participate in a second Heat.

A maximum of 2 cars can be move up to Semi-/Final if a driver is not able to start.

The driver who causes a false start in a Heat, Semi-/Final must do the Joker Lap for a second time.

If there is no Joker Lap available, the driver who causes a false start in a Semi-final or Final will be fined by 10 seconds resp. for a false start in a heat by 3 seconds.

A judicial camera is obligatory. Throughout the Competition, all Competitors must have installed in their car a judicial camera. It is the responsibility of each Competitor to ensure that the camera is positioned in such a way that the track and the steering wheel are clearly visible, that the camera batteries are sufficiently charged and that the SD recording card is in place and has sufficient capacity to record all of the races. The penalty (up to exclusion from the Competition) for non-compliance will be at the discretion of the stewards. The weight of the camera system is included in the minimum weight of the car. The onus is on the Competitor to ensure the judicial camera is switched on and recording for all practice sessions, races, Semi- Finals and Finals. The camera must work as soon as the car enters the pre-grid area and must not be switched off until it returns to the paddock. Championship officials must be able to access the footage at all times during the Competition following a protest or otherwise. The images must be viewed using the equipment (computer) of the Competitor, who must ensure this equipment is working.

Exception: It will be allowed to use the whole paddock as parc fermé area.

7.5 Classification

The classification will be done according the 2023 SPORTING REGULATIONS OF FIA EUROPEAN RALLYCROSS CHAMPIONSHIP Art. 15.6 to 15.8.

In Division SuperTouringCars class -1600 cc and class -2000 (+1600-2000) cc and class +2000 cc will run separately, each class will get championship points.

The following drivers will be declared winners of the Central European Zone Rallycross Championship at the end of the year:

- The driver having scored the most points in Division SuperCars
- The driver having scored the most points in Division Super1600
- The driver having scored the most points in Division STC-1600
- The driver having scored the most points in Division STC-2000
- The driver having scored the most points in Division STC+2000

CEZ TECHNICAL REGULATIONS FOR RALLYCROSS CARS

Voice radio communication between the driver and his team is allowed in all divisions. The use of a protective polycarbonate windshield film is strongly recommended for all RX divisions.

The use of diesel engines is prohibited.

DIVISION AND CLASSES

1. SuperCars

- cars homologated in group A = 4x4 cars with a max. engine capacity of up to 3500 ccm and cars with one driven axle with an engine capacity exceeding 4000 ccm, corresponding to Appendix J of the ISC FIA (Article 251-255) with a max. range of modifications according to the current Appendix J of the ISC FIA (Article 279). The air restrictor for turbocharged engines shall have an internal diameter of not more than 45 mm (see Figure 254-4).
- cars 4x4 up to 4000 ccm with expired homologation or cars with one driven axle with an engine capacity of more than 4000 ccm, complying with the regulation according to Article 279 of Appendix J of the FIA ISC for Division 1 cars in the year of completion of homologation and exceptions according to the technical regulation of the ASN's. The weight limits are the same as for SuperCars. For cars with a volume of +3500, the minimum weight is **1380 kg**.

2. Super 1600

- cars homologated in group A and corresponding to Appendix J of the ISC FIA (Article 251-255) with a max. extent of modifications according to Appendix J of the ISC FIA (Article 279).

3. SuperTouringCars

- at least 4-seaters (including 2+2), series-produced vehicles (min. 2500 units during 12 consecutive months) with one driven axle and a fixed, non-removable roof, manufactured after 1.1.1984, which comply with the SuperCars regulations referred to in Articles 279.1 to 279.3 of Appendix J of the ISC FIA (except Articles 5.3, 5.4, 5.5)
- only vehicles of manufacturers listed in the FIA homologation list are recognised for this Regulation

A. TECHNICAL REGULATION OF THE DIVISION SUPERTOURINGCARS (STC)

0. Introduction

Unless otherwise specified in this Regulation, Articles 251 (Classification and Definitions), 252 (General Regulation), 253 (Safety Equipment) and 279 of the Appendix J of the ISC FIA shall apply. Variable timing motors are allowed.

01. Definition

STC car:

Minimum 4-seater (including 2+2), touring, mass-produced wagons (min. 2500 units during 12 consecutive months) with a fixed, non-removable roof, with one-axle drive, manufactured after 1.1.1984, which comply with the regulations for STC vehicles (max. capacity 4000 cc, turbocharger with max. diameter 45 mm, catalytic converter any, max. noise limit 100 dB, safety equipment of the vehicle according to the FIA Standards (safety tanks with a maximum capacity of 20 litres with an extended service life of 5 years, safety seats with an extended service life of 5 years and the Technical Regulation for the STC Division (only vehicles of manufacturers listed on the FIA homologation list are recognized for this regulation).

Announcement for year 2026 onwards: all safety equipment has to be according valid FIA rules.

STC classes:

- STC-1600 ccm - cars with maximum (and recalculated) engine capacity up to 1600 ccm
- STC-2000 ccm - Cars with a maximum (and converted) displacement over 1600 ccm and up to 2000 ccm
- STC+2000 ccm - cars with maximum (and recalculated) displacement over 2000 ccm

Conversion for turbocharging = 1.7 for petrol engines.

02. Supplements

The car does not have to have FIA homologation, the car manufacturer must be on the FIA list of manufacturers (cars properly sold in the dealership are accepted)

1. Generally

1.1 Engine

The engine and its components are free, but the engine block must come from a car model of the same brand as the body.

1.2 Obligations of the competitor

Upon request, the competitor is obliged to prove to the technical and sports commissioners that the vehicle entered by him complies with the regulations for the entire duration of the event.

1.3 Telemetry / voice communication / cameras

Any form of telemetry, GPS systems is prohibited.

Recording cameras, which scan the area in front of the car and operate throughout the journey, are mandatory.

2. Dimensions and weights

2.1 Minimal weights:

For STC cars applies:

Min. weight of the vehicle with the rider in the car, including its complete safety equipment and including liquids remaining in the vehicle at the moment of weighing, must be according to the converted engine capacity according to the table below:

Engine capacity	Min. weight
to 1000	780 kg
to 1000	870 kg
to 1400	970 kg
to 1600	1070 kg
to 2000	1100 kg
to 2500	1180 kg
to 3000	1270 kg
to 3500	1350 kg

2.2 Dimensions

The wheelbase must remain original, as must the wheelbase of the skeleton model with a tolerance of +/- 1%.

The body width (track) can be increased by 70 mm on each side compared to the original model. The width of the bodywork shall be measured above the axle of the wheels.

3. Engine

3.1 Basic data

Type: The engine is arbitrary, but the engine block must come from a car model of the same original brand as the original body. There may be only one direct mechanical connection between the accelerator pedal and the engine load monitoring device. For STC2000+ turbocharged engines is allowed el. throttle control (according to Art. 279 para. 5.4.2.2. h, J FIA).

Engine location: original space of the brand's model

Engine position: the transverse (or longitudinal) axis of the engine may extend more than 50% beyond the axis of the front wheels towards the rear.

3.2 Airbox, turbocharging

Airbox: free (naturally aspirated engine or turbo engine)
variable suction forbidden

Restrictor:

Turbocharged engines must be equipped with a restrictor with a maximum internal diameter of 45 mm at the turbocharger inlet — see fig. 1 if the diameter of the turbo compressor chamber inlet is greater than 45 mm. The installation of the restrictor on a turbocharger must be carried out in such a way that two screws need to be completely removed from the compressor body or restrictor in order to separate the restrictor from the compressor. The screws must be drilled for sealing. The restrictor is not mandatory if the diameter of the compressor inlet is less than 45 mm (this inlet shall not be a removable part of the compressor housing).

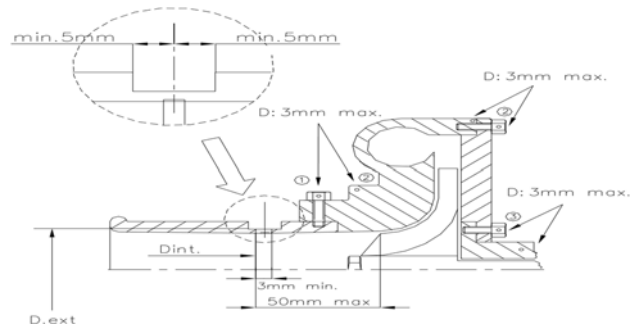

Drawing 1

The outlet of the waste-gate exhaust gas bypass shall be made to the exhaust system and shall not be recycled in any way. In addition, there must be no connection between the intake and exhaust systems. Water injection is prohibited, even if it was originally homologated. Spraying of the charge air intercooler is prohibited. Vehicles with turbocharged engines shall not be fitted with any device enabling the rider to control the boost pressure or with an electronic control system controlling the boost pressure (other than the accelerator pedal) while driving. Ceramics elements, variable diameter inlets and internal blades are prohibited on turbocharges.

<u>Air filter including airbox and location:</u>	free
<u>Filling the engine with fuel:</u>	carburettor or arbitrary injection
<u>Distribution:</u>	variable distribution allowed
<u>Mechanical parts of engine:</u>	free (piston, connecting rod, flywheel, cam, oil hosp...)

3.3 Exhaust

<u>Implementation:</u>	any under the condition of maintaining the max. noise level
<u>Noise:</u>	max. 100 dB (A) in 4500 rpm.
<u>Outcome:</u>	behind half of the wheelbase, not downwards, inside the bodyshell
<u>Catalyst:</u>	none mandatory

3.4 Engine cooling

<u>Type:</u>	any cooler including fan
<u>Location:</u>	any, must not directly interfere with the rider's compartment (separation from the rider's compartment)

<u>Air intakes:</u>	can pass through the rider's compartment, the area of air inlet and outlet to and from the body can be max. the same as the radiator area
---------------------	---

4. Fuel system

4.1 Fuel tank

Types:

Serial or made of Al alloy sheet metal (min. thickness 2 mm + foamless filling – see conditions below) or FIA safety (FT3 standard) with a service life extended by 5 years (5+5)

Conditions for the tank made of sheet metal of Al alloy: It must be made of aluminium sheet with a minimum thickness of 2 mm and the material must comply with EU standard No. EN-AW1052A-H24. Maximum volume 20 litres.

- Tank welding shall be carried out by a licensed non-ferrous metal welding officer.
- The inside of the tank must be filled with safety foam (material) according to US standard no. MIL-B-83054.
- The safety foam can be replaced by using a "D-STOP" anti-explosive foil on the outside of the tank.
- No anchorages shall be welded to the tank and the tank shall be fixed to the rigid structure of the wagon only by means of strips of metallic material.
- The inlet and outlet pipes from the tank shall be of a flexible type to prevent rupture of the tank or the pipes due to deformation.
- The tank shall be separated from the crew compartment and at least 300 mm from the extreme outer edge of the vehicle when viewed from above. Partitions shall be provided in accordance with Article 279A 3.12.1.

g) Tank venting shall not be led out into the crew compartment or engine compartment. It shall be equipped at least with a gravity ventilation valve located on the tank.

h) The conditions of points (a) to (d) shall be documented when testing the vehicle.

Location: min. 300 mm from the skeleton (except serial), impermeably separated from the space for driver. If a series fuel tank is used (always in the original position only), the condition of a distance of 300 mm from the contour of the vehicle when viewed from above need not be complied with.

Filling: Safe, multifunctional valve (function: overpressure, gravity, ventilation) Overflow protection

Fuel collection valve: none mandatory

4.2 Fuel pumps, circuit – type of connections, fuel collection valve

Pumps: type any, separate from the rider's compartment, operating only in conjunction with the engine running except for starting.

Fuel line, type of connections:

Fuel lines shall be damage-resistant, fireproof, bolted, in a crew compartment without joints, separate from the rider's compartment.

4.3 Fuel

Acc. to FIA (BA, NM).

5. Electrical equipment

5.1 Battery, wiring

Battery:

Type: free

Location: any with limited placement in the rider's compartment, where it must always be behind the level of the backrest

Fixation: always laid on metal. bed, attached by 2 screw callipers min. M8 wet in the D area completely covered by a non-conductive ventilated cover, dry in the D area with the + pole covered. Batteries located outside the J area must always have a covered + pole

Wiring: Securely made and covered connections, non-conductively insulated live conductors

5.2 Generator

Type: any including location. Nominal voltage 12 V.

5.3 Lighting System

Lights

Rear: 2 x red STOP light (60 cm²) + 1 x red fog lamp, located in suitable height in relation to the car behind it, not covered by the wing

Front: the original lights must be removed and the holes covered with plastic.

The lights must be lit even when the disconnecter is in the OFF position.

6. Gears

6.1 Clutch

Type: lamellar, hydraulically operated by pedal, other arbitrary

6.2 Gearbox

Type: mechanically (manual) gearbox (sequential, synchronous system Hewland, synchronized), automatic transmissions prohibited

6.3 Gearbox case

Number of gears: free

Sizes of gear ratios: free

Final drive: free

6.4 Shafts

Design: any design of half-axles and ev. and longitudinal shafts

6.5 Differential

Type: mechanical, self-locking. The use of a differential with a viscous clutch is allowed. Differential control el. magnet is prohibited.

7. Suspension

7.1 Reinforcement, replacements

Reinforcement of suspension elements and their attachment points is permitted if the reinforcement material copies the original shape and touches it (applies to suspension elements and suspension attachment points). The suspension reinforcement shall not form hollow bodies or allow two different parts to be joined together. Silent blocks and slide guides can be replaced by the "Uniball" system.

Changing the settings of springs and dampers from the crew compartment is prohibited.

Demountable steel sub-frames for fixing the axles (suspension) are permitted (however, the frame for the front axle must not be connected to the frame for the rear axle). Changes to the skeleton, necessary for the location of suspension elements, drive shafts, compl. bikes are allowed. The maximum number of frame attachment points is 6.

Active suspension is prohibited.

7.2 Front axle, suspension points

Design: acc. to App. 279 - 8.2 App. J ISC FIA

Front shock mount: to store the shock absorber, it is possible to use an atypical hat of the upper bearing including the upper mounting plate.

7.3 Rear axle, suspension points

Design: acc. to App. 279 - 8.3 App. J ISC FIA

Rear shock mount: to accommodate the shock absorber, it is possible to use an atypical hat of the upper bearing including the upper mounting plate within the dimensions according to drawing 279-1.

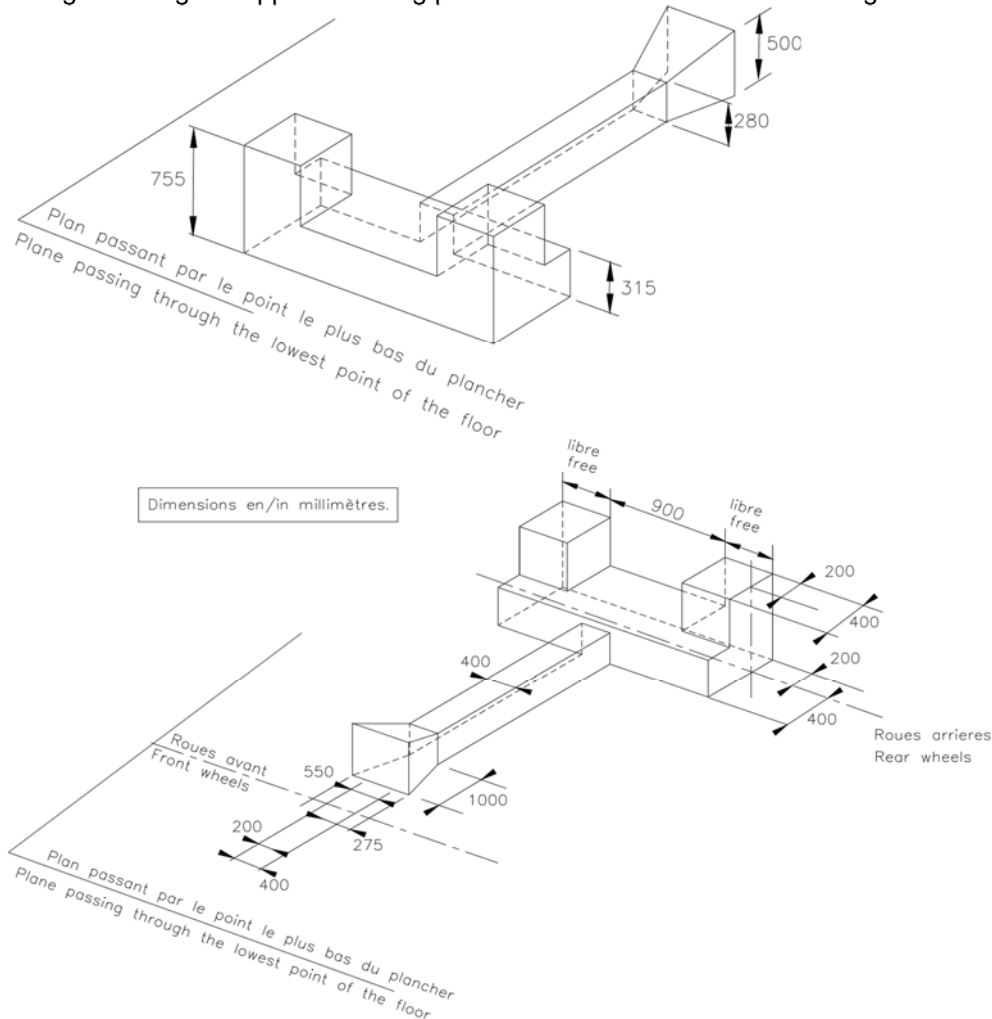

Drawing 279 - 1

7.4 Springs

the length is arbitrary, as well as the number of coils, wire diameter, outer diameter, spring type (progressive) and spring seat shape. The number of springs and seats is arbitrary, provided that the springs are mounted in series.

7.5 Stabilizer

The stabilizer can be disconnected or removed.

7.6 Shocks

Number on wheel: one on wheel

Type, function: free

Mark: free

Shock travel: free

7.7 Reinforcing struts

Reinforcing struts can be attached to mounting points on the body. The condition is that the struts are removable and are attached by a weld or bolts or pins.

The distance between the suspension attachment point and the strut attachment point shall not exceed 100 mm

8. Chassis

8.1 Wheels

Dimensions: max. disc diameter 18", complete wheel (tyred) with width must fit in U 250 mm

8.2 Tyres

Tyre tread pattern is free

8.3 Brakes

Brake system: dual-circuit hydraulic system, controlled by one pedal, others arbitrary

System ABS: must be removed – decommissioned

Mud scraping equipment from discs and/or wheels may be added.

A device can be fitted to protect the brake discs from flying stones.

8.4 Parking brake

Design: a working handbrake is mandatory, on which it is allowed

- replace the mechanical handbrake with a hydraulic system
- change the position of the hand-held hydraulic brake lever, provided that it remains on the central tunnel
- Adjust the handbrake lever mechanism for immediate release (fly-off system).

8.5 Safety

The brake (clutch) fluid reservoirs shall be separated from the D compartment.

8.6 Steering, steering wheel, steering column

The steering column need not be fitted with a deformation or retractable element.

Steering rod bearing reinforcements:

It is possible to add stiffeners under the following conditions:

- must be approved prior to installation by the Technical Committee.

Steering wheel: arbitrary, no quick-sensing device required

9. Bodywork

9.1 Interior, safety equipment (safety construction, seats, belts, extinguishing system, fire extinguisher)

Ventilation system:

Additional installation of equipment for ventilation of the crew compartment (roof air flap h x w = 100 x 500 mm or in side windows) is permitted.

Heating:

The original heater may be removed, but the electric demisting system must be retained (applies to the closed car).

AC: can be removed

Panel:

the dashboard is arbitrary, but it must not pose any danger to the rider.

The centre console can be removed.

Floor:

the floor in the D compartment shall be completely enclosed.

Other soundproofing materials and linings:

It is allowed to remove soundproofing material and lining.

Fluid reservoirs, coolers, pressure pipes:

Fluid reservoirs, coolers, pressure piping and hoses shall be consistently separated (by impermeable cover, bulkhead) from the rider. The rider's compartment must not show dangerous structures (sharp edges, projections, etc.)

9.2 Safety equipment

Safety cage:

The minimum configuration of the protection structure must correspond to the requirements for the min. configuration according to Appendix j of the ISC FIA art. 253-8 drawing 253-36B.

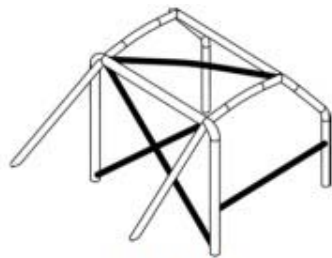

253-36B



253-36C

The decisive factor is the date of homologation (start of production of the serial car) and the decision of the Technical Commission when permitting the construction of the car.

For vehicles manufactured before 31.12.2004, the main arch, including any side half-arches, and other elements of the safety structure, may be made of a material with a minimum size of 40 x 2 mm or 38 x 2,5 mm, subject to the conditions laid down in Article 253.8 of Appendix j of the ISC FIA.

The mounting plates of the main cage (stands) of the protective structure do not need to be bolted to the skeleton reinforcement plate (a weld connection is sufficient)

There must be reinforcement of safety cage, if measure A is more than 200 mm

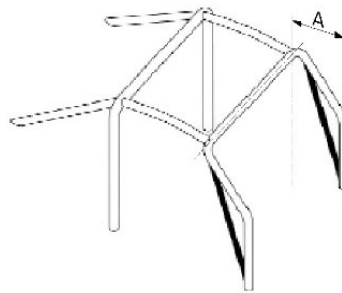

253 - 15

These combinations are minimal, for other options see only App. J FIA Art. 253.8.

Attention: under the anchorage points it is necessary to reinforce the skeleton with sheet metal of thickness. 3 mm.

Material and dimensional specifications:

According to App. J

At the point of possible contact of the helmet or body of D with the protective structure, the structure must be lined with a non-combustible material (foam).

Seats, brackets:

It is permitted to move the front seats, but not beyond the vertical plane defined by the front edge of the seat cushion of the original rear seat.

An FIA-approved seat is mandatory (standard 8855/1999 - use limit 5 + 5 years from the date of manufacture or 8862/2009 - use limit 10 + 5 years from the date of manufacture, see Art. 253.16 App. J FIA)

Brackets:

According to Art. 253.16 app. J (crossbars between sill and tunnel + angle of aluminium alloy of min. thickness 5 mm or steel of min. thickness 3 mm + 4 anchor strength bolt joints min. M8 for seat and for holder)

Safety belts:

5 - 6-point, approved according to FIA standard 8853/98 or 8853-2016 with hologram and valid service life, installation according to Art. 253.6.2 App. FIA.

Fire extinguisher:

Mandatory manual fire extinguisher 2 kg with valid revision (manual HP inspection technician). The HP bottle must be properly attached including axial locking. The HP installation must be within reach of the driver.

Fire system:

Built-in FIA-approved fire extinguishing systems are recommended for cars with windscreens.

Additional bonnet and lid attachments:

At least 2 additional attachments must be installed on the hood and lid.

Towing eyes:

Mandatory towing eye front and rear, marked with an arrow and contrasting colour.

Disconnecter of electric energy:

Mandatory external and internal must disconnect all el. circuits and be designated according to Article 235.13 of Annex J.

9.3 Exterior, reinforcement, windows, chassis protection, side protection

Bodywork

The body can only be modified beyond the vertical plane touching the rear wheels and in accordance with fig. 279-1.

The rear longitudinal beams can be adjusted from the axis of the rear wheels.

It is also possible to reinforce the body with stiffeners that do not copy the original shape (they create a profile).

When all these modifications are applied, the supporting function of the basic skeleton must be maintained.

Central (transmission) tunnel

The dimensions must be equivalent to or less than those shown in Figure 279-1, the location may have tolerances of **+/- 100 mm** in the Y-direction, modification according to fig. 279-2 is permitted for the installation of a catalytic converter or silencer

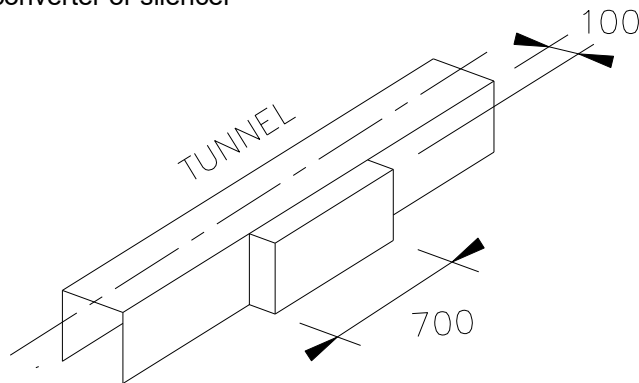
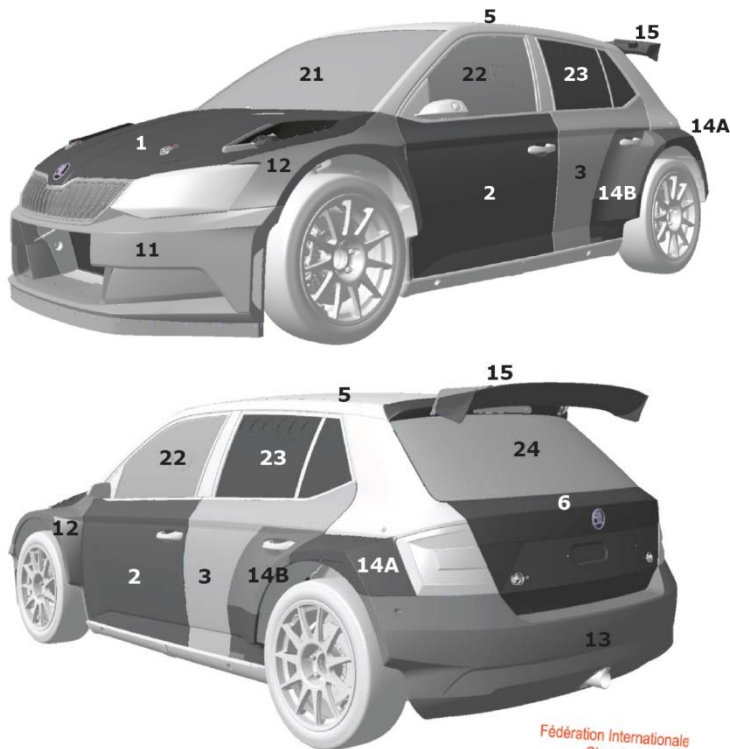

Fig. 279-2

Material specification of the skeleton and surface parts

Skeleton	- steel	
Floor	- steel	5
Front, rear fender	- free	12,14
Front bumper + spoiler	- laminate, plastic	11
Rear bumper	- laminate, plastic	13
Rear wing	- laminate, plastic	15
Holder of rear wing	- Al alloy	
5. door	- free	6
Bonnet	- free	1
Floor protection (optional)	- plastic	
Drivers' door	- original	2
Others doors	- free	3



Sound insulation materials can be removed from the inside of the wheel arches, the engine compartment and the luggage compartment. These materials can be replaced by panels (covers) made of sheet metal of aluminium alloy or plastic.

It is allowed to remove exterior decorative mouldings.

Windows:

Front window (pos. 21): original or polycarbonate (Makrolon, Lexan) th. 5 mm

Side window on drivers' side (pos. 22): original or polycarbonate (Makrolon, Lexan) min. th. 4 -0,2 mm

Side and rear windows (pos. 23, 24): original or polycarbonate (Makrolon, Lexan) min. th. 3 -0,2 mm

If windows are replaced by metal mesh, they shall have meshed of a minimum size of 10 × 10 mm and a maximum of 25 × 25 mm, using wire with a minimum diameter of 1 mm.

If a wire with a minimum diameter of 2 mm is used at the driver's door, a protective net need not be installed.

The wagon shall be equipped with working windscreen wiper(s) and working washer (for a closed car)

It is allowed to remove the lower cladding of the windshield (window).

A windscreen lower trim may be modified according Art. 279-10.2.4 of App. J ISC FIA.

Doors, side protection:

It is allowed to remove the upholstery and soundproofing material of the door and ev. from the space under the rear side window (2 door car) and replace it with a panel of sheet metal of aluminium alloy with a thickness of at least 0.7 mm or a panel of non-combustible material of thickness. min. 2 mm. The rider's door must be original, including material. The door reinforcement can only be removed under the condition that it will be replaced without security. foam with a volume of min. 60 l.

Bonnet

The shape of the bonnet shall be based on the shape of the original bonnet. The bonnet does not need to be replaceable by a standard bonnet. The maximum deviation from the original shape of the bonnet may be 100 mm (measured vertically).

The bonnet can only be modified (adding openings and inflators) to improve the air intake and heat dissipation to and from the engine compartment. The modification must not imply an improvement in the aerodynamic properties of the car. The holes in the hood must be covered with a grid, the attachment must be made through 4 points (pins), the original locks must be removed (pos. 1 and 6).

Bumpers:

For fixing the bumpers, it is allowed to add additional fastenings (in addition to the original fastenings, which must be preserved), however, the formation of so-called "rams" is prohibited.

Fenders:

Due to the possible extension by the permitted 2 x 70 mm, it is possible to attach a rim made of min. thickness material to the mudguards. 2 mm. The collar (mudguard) must cover the wheel in such a way that it cannot be seen above the wheel axis when viewed from above.

Aerodynamic elements

Front aerodynamic element:

Material and shape of the concept arbitrary, limited:

- a vertical plane passing through the axis of the front wheels and a horizontal plane passing through the highest point of the rim (fig. I - 1),

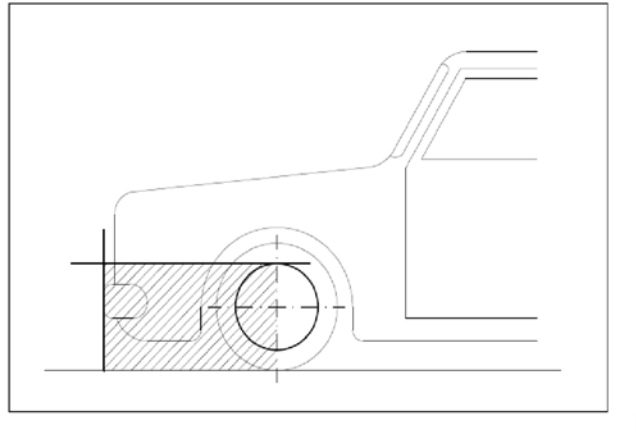

- 1

- the total length of the production car
- towards the front by the vertical projection of the bumper of the original car A hole or holes can be made in the bumper, the total area of which must not exceed 2500 cm². These openings shall not impair the structural integrity of the bumper.

The material thickness of the aero element must be a minimum of 2 mm and a maximum of 5 mm.

Front brace:

it must remain original, without modification and/or may be replaced by a steel pipe according to Annex J, Art. 279, Cap. 10.2.14.

Rear aerodynamical device:

Rear wing – max. dimension: width 1360 mm, the wing side plan must fit into the rectangle h = 290 mm, w = 450 mm

Rear wing - position: the wing must not extend beyond the plan contour of the car

If the vehicle has a homologated original aerodynamic device larger than permitted by the above wording of the regulation (App. J FIA), it may be retained in its original form.

Lower protection:

The lower protection (skid) must not extend beyond the bumper crossbar. Min. th. 4 mm for Al alloy and 2 mm for steel.

10. Driver's Safety Equipment

1. Helmet (acc. TL n. 33, 49)

Mandatory according to standards FIA: 8860-2004, 8860-2010, 8858-2015 and SNELL: SA2010, SAH2010, SA2015.

2. Drivers' equipment (acc. TL n. 27 overall, underwear, balaclava, gloves, shoes)

Mandatory according to standards FIA: 8856-2000 with FIA Hologram label or 8856-2018.

3. FHR (acc. TL n. 36 HANS system, Hybrid system, Hybrid Pro system, HANS Adjustable system) Optional, if used, must be according to standards FIA 8858-2002 or 8858-2010 and in combination with compatible helmet (according to SNELL: SA2010, SAH2010 resp. FIA: 8858-2002, 8858-2010) z TL n. 41

Art. 8. 2025 FIA CENTRAL EUROPEAN ZONE KARTING CHAMPIONSHIP

8.1 Eligible Karts

The Championship will be reserved for the classes:

<u>OK</u>	acc. FIA Karting regulations
<u>OK Junior</u>	acc. FIA Karting regulations
<u>KZ2</u>	acc. FIA Karting regulations
<u>Rotax Micro MAX</u>	acc the regulations of the Global Rotax MAX Challenge regulation and some additional provisions specified in these regulations
<u>Rotax Mini MAX</u>	acc the regulations of the Global Rotax MAX Challenge regulation and some additional provisions specified in these regulations
<u>Rotax Max Senior</u>	acc the regulations of the Global Rotax MAX Challenge regulation and some additional provisions specified in these regulations
<u>Rotax Max Junior</u>	acc the regulations of the Global Rotax MAX Challenge regulation and some additional provisions specified in these regulations
<u>DD2</u>	acc the regulations of the Global Rotax MAX Challenge regulation and some additional provisions specified in these regulations
<u>DD2 Masters</u>	acc the regulations of the Global Rotax MAX Challenge regulation and some additional provisions specified in these regulations

All technical rules published by the FIA Karting or by Global Rotax MAX Challenge for the year 2025 must be respected with the exception of the specific rules prescribed in CEZ regulations

8.1.1. Specific technical prescriptions for ROTAX classes in CEZ championship

Eligible engines

The engines from the Authorized Rotax Distributor of the territory of the drivers ASN accompanied by the identity card and with the last seal set by the service centre appointed by the Authorized Rotax Distributor of the territory of the drivers ASN are the only ones that are allowed to be used, unless the engines are provided by the organizer (Lottery engines).

If CEZ race is organized together with national championship and national championship in its regulations have prescribed lottery engines for some drivers the lottery engines can be used for some drivers in that championship. The organization of lottery, rent fee, rules for changing the engines will be defined in supplementary regulations (S.R.) of the event. Lottery engines must comply with Global Rotax MAX Challenge regulations for 2025.

Carburettor: According to Global RMC technical regulation for 2025.

The organiser of the event in the S.R. can specify the minimum diameter of the main jet for each Rotax class. The minimum diameter will be checked by a plug gauge and not by a marking on the main jet.

Fuel: Organizer of the event can specify one gas station and one fuel from that station (close to the track) that will be used as an official fuel for the event. In all Rotax classes fuel has to be mixed for at least first five, recommendation for all. Fuel tank of the driver can be exchanged with the fuel tank given from organizer before each race or qualifying practice.

Oil: According to Global RMC technical regulation for 2025.

Chassis in all classes must be in line with Global RMC technical regulation for 2025.

8.1.2. Tyres

All dry tyres used on the event must be supplied by the organizer and must be in accordance with the regulations for the specific class. The organizer must specify the prices of the tyres in the S.R. of the event. The organizer must provide the additional tyres for practice session for the same price.

For Rotax classes the prices of tires will be set as standard retail price of the tyre plus VAT that depends on the country of the organizer. The list of retail prices will be defined by the end of January and will be shared between the members of the working group and by the organizers of the events.

For OK, OK Junior and KZ2 a single tyre manufacturer will be defined for one event. Only the homologated tyre according to FIA KARTING General prescriptions is allowed. The tyre manufacturer and the model will be defined by the S.R of the event.

The number of slick tyres for one event is restricted to one complete set. In the event of a slick race tire being damaged, the technical scrutineer may allow the competitor to nominate a "USED" tire of similar

wear from the drivers practice tires as a replacement. The damage must be reported to the scrutineer immediately after the on-track action where the damage occurred, and prior to leaving the parc ferme / scale area

These registered tyres must be used from qualifying practise and must be new on qualifying practise, if the dry tyres are used. The number of wet tyres is not limited (free) and can be used according to the CIK-FIA General prescriptions, Article 2.14 s). Wet tyres that are used in Qualifying practice and/or races must be registered by scrutineers.

EXHAUSTS

- Lottery for exhausts – minimum 5 exhausts (for all ROTAX categories)
- Lottery exhausts stay in Parc Ferme

8.2 Events counting towards the Championship

Venues and dates according the FIA-CEZ- Championship-Calendar; see www.cez-motorsport.com. An individual CEZ event does not have to include all the classes specified in point 11.1. At the time of the entry of the event into the CEZ calendar the ASN that proposes the event has to specify for which classes the event will be held. The S.R. that will follow also have to specify the classes that count for the CEZ championship.

8.3 Organisation of the events

The event has to be organised according to the FIA-Sporting Code and its Appendices and also according the FIA Karting regulations and the basic S.R. for this Championship. The format of the S.R. will be unique and will be available through the CEZ secretariat or Karting working group. The S.R. must be published on official CEZ website, on some other CEZ Karting communication platform or sent to each CEZ ASN 30 days before the event. If this deadline is not met the event will not count for CEZ Championship.

If the event hosts Rotax classes Chief scrutineer must have certificate from Rotax about training program for Scrutineers and must be from ASN that is not hosting the event. Chief scrutineer must not serve as tuner or official service for Rotax engines within the CEZ Zone countries.

If the event is organized together with national championship or some other series the CEZ Regulations must be enforced. Drivers which compete only on national event or in some other series event must comply with CEZ regulations except for Drivers that belong to ASN that is not in CEZ-ZONE, but according to National regulations can drive for points in National championship or for trophies on the event (day drivers) can drive together. In that case the driver cannot count for the CEZ Championship. Also, the lottery engines for drivers in national championship can be enforced as specified in 8.1.1.

The list of entered drivers has to be made publicly available by Wednesday of the week of the event. Late entries are possible, but must be defined in the S.R. The organizer of the event can cancel the event if he does not have a specific number of valid entries after the deadline for entries has passed. The minimum number of valid entries for the event will be defined in the supplemental regulations. If the event is cancelled all paid entry fees have to be returned.

Entry fee: The entry fee can be maximum 250 EUR plus VAT. The exact entry fee with VAT must be specified in the S.R.

Organizer of the event can set maximum number of entries for one class. The maximum number of entries cannot be lower than 1.5 x maximum number of karts on track defined by the track licence (e.g. 1.5 x 34 = 51). If the number of entries is limited the organizer must define the number and selection process in the S.R. of the event.

One driver will have the same race number on all CEZ events.

8.4 Classification

For each event three sets of points following the scale defined below will be awarded:
25, 20, 16, 13, 11, 10, 9, 8, 7, 6, 5, 4, 3, 2, 1.

If the number of drivers in the class on the event is less than maximum number of karts on track defined by the track licence the points will be awarded from three individual races. The start order of first race will be based on Qualifying practice while the start order of Race 2 will be based on the results of Race 1 and for Race 3 based on the results of Race 2.

If the number of drivers in the class on the event is higher than maximum number of karts on track defined by the track licence the Qualifying heat system must be applied. Based on the Qualifying practice (CIKFIA Specific prescriptions Article 18b) drivers are divided in at least 3 groups and Qualifying

heats with each group driving with all other groups will be organized. From Qualifying heats based on point scoring system described in CIKFIA Specific prescriptions Article 18c the ranking will be obtained. From that ranking the number of drivers that is equal to maximum number of karts on track defined by the track licence starting with first in ranking to maximum number will enter the final two races. The first set of points for the Championship is obtained from Qualifying heat ranking, while the second and third set of points is obtained from the results of Final 1 (Race 2) and Final 2 (Race 3). The starting order for Final 1 is based on ranking from Qualifying heats while the start of Final 2 is based on the results of Final 1.

Points will be awarded to all drivers that position themselves in pre-grid and are ready to race, according to the classification. If driver receives DQ no points will be given.

For the classifications at the end of the year, the (X-7) best results of all races (sets of points) will be taken into account, where X is the number of held races during championship season. Number X can not be lower than 21. If a driver during championship has a certain number of DQs then the number of races that he can sum up for final classification is lowered by the number of DQs. If the number of held races is 13 or lower all held races will be taken into account and summed up for final classification.

If two drivers have the same number of points at the end of the year, the following conditions, one after another, will be used in the classification:

- The driver that achieved larger number of better places in the races will be classified higher.
- The driver that achieved larger number of better places in the qualifying practices of the events will be classified higher.
- The driver that participated on more events will be classified higher.

At the end of the season the class in CEZ-Karting Championship will have its final results and will be able to declare FIA - CEZ Champions, if at least one driver in a class has scored points in at least three different countries or on the events organized by three different ASNs and if the class contains minimum 10 eligible participants; otherwise, the results of that class will be deleted.

The following drivers will be declared winners of the Central European Zone Karting Championship at the end of the year:

- The driver having scored the most points in Class OK
- The driver having scored the most points in Class OK Junior
- The driver having scored the most points in Class KZ2
- The driver having scored the most points in Class ROTAX Micro Max
- The driver having scored the most points in Class ROTAX Mini Max
- The driver having scored the most points in Class ROTAX Max Juniors
- The driver having scored the most points in Class ROTAX Max Seniors
- The driver having scored the most points in Class DD2
- The driver having scored the most points in Class DD2 Masters

If the drivers age allows him to participate in Senior and Junior category the driver will not be able to participate in Junior category if he/she participated in any international or zone competition in the Senior category prior to the event under consideration.

Art. 9. 2025 FIA CENTRAL EUROPEAN ZONE HISTORIC RALLY CHAMPIONSHIP

9.1 Eligible Cars

The Championship is reserved for vehicles as per App. K:

- **Category 1:**
Road legal cars built between 1/1/1931 and 31/12/1957 and Touring and GT cars, model homologated between 1/1/1958 and 31/12/1969:
 - 1A** up to 1300 cc,
 - 1B** from 1301 cc to 1600 cc,
 - 1C** over 1600 cc,
- **Category 2:**
Touring (T), Competition Touring (CT), Grand Touring (GT) and Competition Grand Touring (GTS) cars of Groups 1 to 4, model homologated between 1/1/1970 and 31/12/1975:
 - 2A** up to 1300 cc,
 - 2B** from 1301 cc to 2000 cc,
 - 2C** over 2000 cc,
- **Category 3:**
Touring (T), Competition Touring (CT), Grand Touring (GT) and Competition Grand Touring (GTS) cars of Groups 1 to 4, model homologated between 1/1/1976 and 31/12/1981:
 - 3A** up to 1600 cc,
 - 3B** from 1601 cc to 2000 cc,
 - 3C** over 2000 cc,
- **Category 4:**
Touring (T), Competition Touring (CT), Grand Touring (GT) and Competition Grand Touring (GTS) cars of Group A, B and N, models homologated between 1/1/1982 and 31/12/1987 (Period J1) and models homologated between 1/1/1988 and 31/12/1992 (Period J2):
 - J1A** Two wheel drive up to 1600 cc,
 - J1B** Two wheel drive up to 2000 cc,
 - J1C** Two wheel drive above to 2000 cc,
 - J1D** Four wheel drive
 - J2A** Two wheel drive up to 1600 cc,
 - J2B** Two wheel drive up to 2000 cc,
 - J2C** Two wheel drive above to 2000 cc,
 - J2D** Four wheel drive

Competitors competing in Category 4 are required to comply with the FIA Regulations in Appendix XI of Appendix K.

In case of supercharging (see definition in the current Appendix J), the nominal cylinder capacity of all cars up to and including Period J1 will be multiplied by 1.4 and that of cars of Period J2 by 1.7. Each car will belong to the class corresponding to the fictive cylinder capacity thus obtained.

All cars must be registered for open public road use.

For safety reasons, mid- and rear-engine two-seater racing cars shall not be admitted to the Championship.

A valid Historic Technical Passport (HTP) from FIA or a Zone-member ASN, comparable to the FIA-HTP, must be provided at the scrutineering for every event by the competitor for every car entered; Every entry form for an event must be accompanied by a photocopy of the first page of this HTP (other national car passes or documents are not accepted for this Championship).

All cars must be registered for open road use.

9.2 Events counting towards the Championship

Venues and dates according the FIA-CEZ- Championship-Calendar; see www.cez-motorsport.com).

Should the number of qualifying rallies organised finally be less than three, the Championship would be considered as not having taken place.

9.3 Organisation of the events

The total distance of the special stages shall not be less than 50 km and not more than 300 km, with special stages not longer than 30 km each.

The use of any sort of device to warm tyres is forbidden.

9.4 Classification

At the end of each qualifying event a general classification for each category and class mentioned in Art. 9.1 will be established.

For each category, points will be allocated to the drivers (principle driver and his co-driver nominated by the driver) as follows: 8, 6, 5, 4, 3, 2, 1 and 1 for all other finishers.

For classes with 2 or more starters: 10, 8, 6, 5, 4, 3, 2, 1.

For classes with less than 2 starters: 5.

Points are awarded by category and may not be transferred or combined with points in a different category.

In case of a dead-heat the higher number of points achieved at the 1st, 2nd, 3rd etc. event will be considered.

The following drivers will be declared winners of the Central European Zone Historic Rally Championship at the end of the year:

- The drivers (driver and nominated co-driver) having scored the most points in Category 1
- The drivers (driver and nominated co-driver) having scored the most points in Category 2
- The drivers (driver and nominated co-driver) having scored the most points in Category 3
- The drivers (driver and nominated co-driver) having scored the most points in Category 4

Art. 10. 2025 FIA CENTRAL EUROPEAN ZONE HISTORIC HILL CLIMB CHAMPIONSHIP

10.1 Eligible Cars

The Championship is reserved for vehicles as per App. K:

The update of categories and classes will be posted after the publication of the FIA Sporting Regulations

Category 1 (Period: C, D, E, F, G1, GR):

Category 1.1: (SAL 1-4, OT 1-4, OS 1-8, T 1-15, GT 1-17, TC 1-15, GTS 1-17)

Class A1	up to	850 cc
Class A2	up to	1150 cc
Class A3	up to	1300 cc
Class A4	up to	1600 cc
Class A5	up to	2000 cc
Class A6	over	2000 cc

Category 1.2: (TSRC 1-18, GTP E-G1, HST 1-5, HS 2-6 2 seat)

Class A7	up to	1300 cc
Class A8	up to	1600 cc
Class A9	up to	2000 cc
Class A10	over	2000 cc

Category 2 (Period: G2, H1, HR)

Category 2.1: (T 16-25, TC 16-25, GT 18-27, GTS 18-27)

Class B1	up to	850 cc
Class B2	up to	1150 cc
Class B3	up to	1300 cc
Class B4	up to	1600 cc
Class B5	up to	2000 cc
Class B6	over	2000 cc

Category 2.2: (TSRC, HST 1-5, S 2/1)

Class B7	up to	1300 cc
Class B8	up to	1600 cc
Class B9	over	1600 cc

Category 3 (Period: H2, I, IR)

Category 3.1: (T 26-35, TC 26-35, GT 28-37, GTS 28-37)

Class C1	up to	1300 cc
Class C2	up to	2000 cc
Class C3	over	2000 cc

Category 3.2: (TSRC, HST 1-5, S 2/2)

Class C4	up to	2000 cc
Class C5	over	2000 cc

Category 4 (J1, J2, JR)

Category 4.1: (T, CT, GT, GTS - 01.01.1982 to 31.12.1985)

Class D1	up to	1600 cc
Class D2	up to	2000 cc
Class D3	over	2000 cc

Category 4.2: ((T, CT, GT, GTS - 01.01.1986 to 31.12.1990)

Class D4	up to	1600 cc
Class D5	up to	2000 cc
Class D6	over	2000 cc

Category 4.3: (TSRC, Group C, S 2/3, GC 1a, GC 1b, GC 2a, GC 2b, SN2500, SN3000)

Class D7	up to	2000 cc
Class D8	over	2000 cc
Class D9	SN up to	2500 cc
Class D10	SN up to	3000 cc

Competitors competing in Category 4 are required to comply with the FIA Regulations in Appendix XI of Appendix K.

Group A and Group B cars regulated out by the FIA (see App. K, Art. 7.4.1) are not accepted.

Category 5 (Period C, D, E, F, GR, HR, IR, JR - Single Seat)

Class E1	1919-1953	no capacity limitation
Class E2	1954-1982	up to 1600 cc
Class E3	1954-1982	up to 2000 cc
Class E4	1983-1990	up to 1600 cc
Class E5	1983 1990	up to 2000 cc

In the case of supercharging (see definition in the current App. J) the nominal cylinder capacity of these cars up to and including Period J1 will be multiplied by 1,4 and that of cars of Period J2 resp. JR/1986-1990) by 1,7. Each car will belong to the class corresponding to the fictive cylinder capacity thus obtained.

Bumpers: may be removed, provided the weight of the car is in accordance with the minimum weight specified on its homologation form.

Tyres: cutting of road tyres is forbidden, cars of period G2 may use slicks. The use of any sort of device to warm tyres is forbidden.

At the scrutineering for each event a valid Historic Technical Passport (HTP) from FIA or a Zone member ASN, comparable to the FIA-HTP, must be provided by the competitor for the car entered (other national car passes or documents are not accepted for this Championship).

Every entry form for an event must be accompanied by a photocopy of the first page of this HTP.

10.2 Events counting towards the Championship

Venues and dates according the FIA CEZ Championship Calendar; see www.cez-motorsport.com).

Should the number of qualifying events organised finally be less than three, the Championship would be considered as not having taken place.

10.3 Organisation of the events

The length of the course shall be at least 3,5 km. All events shall have standing starts. During the event it is permitted to push-start cars at any point of the course, but only under the control of race-officials.

10.4 Classification

The classification will be done acc. to the rules specified in the Supplementary Regulation of the specific event.

At the end of each qualifying event a general classification for each category and class mentioned in Art.10.1 will be established.

For each category, points will be allocated as follows: 10 - 8 - 6 - 5 - 4 - 3 - 2 and 1 for all other finishers.

For classes with 3 or more starters: 10 - 8 - 6 - 5 - 4 - 3 - 2 - 1.

For classes with less than 3 starters: 5 - 4.

Points are awarded by category and may not be transferred or combined with points in a different category.

In case of a dead-heat the higher number of points achieved at the 1st, 2nd, 3rd etc. event will be considered.

The following drivers will be declared winners of the Central European Zone Historic Hill Climb Championship at the end of the year:

- The driver having scored the most points in Category 1
- The driver having scored the most points in Category 2
- The driver having scored the most points in Category 3
- The driver having scored the most points in Category 4
- The driver having scored the most points in Category 5

Generally current European Historic Hill Climb Championship regulations are applied.

Art. 11. 2025 FIA CENTRAL EUROPEAN ZONE CROSS COUNTRY CHAMPIONSHIP

11.1 Eligible Cars

- **Group Ultimate** (T1) - according FIA rules
- **Group Stock** (T2) - according FIA rules (also cars with expired homologations) and/or according to ASN national regulations (cars with national ASN's homologations and cars with expired homologations).
- **Group Challenger** (T3) - according FIA rules.
- **Group SSV** (T4) - according FIA rules without restrictor.
- **Group Truck** (T5) - according to FIA rules and/or according to ASN national regulations. This group will be allowed to start only when the organisational conditions of competition allow it.
- **Group TH** - cars with 2 or 4-wheel-drive; closed bodywork (also vehicles with expired homologations). Air restrictor, suspension travel limit and minimum weight according to actual FIA Cross-Country Rallies General Prescriptions and actual Art. 285 of App. J. Turbocharged petrol engines are allowed with air restrictor in compliance with actual Art. 284-6.1 of App. J and maximum internal diameter of 32 mm. For vehicles with turbocharged petrol engines the cylinder capacity multiplying coefficient is 1.7.

Each car without valid FIA Technical Passport must be accompanied by a confirmation of the parent ASN that the car corresponds with the required FIA regulations.

All cars must correspond to the safety prescriptions of the FIA App. J with the possibility, that homologation of the safety equipment can be expired (no more than 5 years from the date of expire) - just as fuel tanks can be in their original place or can be manufacturer's commercial or approved by ASN, setting acc. relevant safety prescriptions. For cars from Groups T1, T2, T3 it is obligatory to use extinguishing systems homologated by FIA (FIA Technical Lists n° 52 or n° 16).

The cars should correspond to the road traffic prescriptions.

11.2 Events counting towards the Championship

Venues and dates according the FIA CEZ Championship Calendar; see www.cez-motorsport.com. Should the number of qualifying rallies actually organised be less than three, the Championship would be considered as not having taken place.

11.3 Organisation of the events

The events are to be organised according to the FIA Sporting Code and its Appendices and especially in conformity with the FIA Cross Country Regulations. Baja Cross Country events and Sprint events are taken into consideration for this Championship. Events can be set up for 2 or 3 days – including the administrative and technical verifications.

The total distance of the selective sections for each event should be 150 to 600 km; events with more than 300 km overall-length of the special stages will be classified as Coefficient 2 (= double-points).

11.4 Classification

Points will be awarded, to the principle driver correctly entered or designated as such, according to the scale:

25 - 18 - 15 - 12 - 10 - 8 - 6 - 4 - 2 – 1, in each of the groups mentioned in Art. 11.1.

If there are less than 6 starters ½ points will be allocated.

The following drivers will be declared winners of the Central European Zone Cross Country Championship at the end of the year:

- The driver having scored the most points in Group T1
- The driver having scored the most points in Group T2
- The driver having scored the most points in Group T3
- The driver having scored the most points in Group T4
- The driver having scored the most points in Group T5
- The driver having scored the most points in Group TH

Art. 12. 2025 FIA CENTRAL EUROPEAN ZONE SLALOM CHAMPIONSHIP

Art. 12.1 Eligible Cars

The Championship will be reserved for

- Division 1: Group N (incl. R1) and Group A (incl. R2 and R3, WRC & KITC), S2000, SP (all together)
- Division 2: Group E1*, E2-SH*, GT
- Division 3: Group Standard Production Cars ** and Group Improved Standard Production Cars *** (all together)

* = according to the national regulation (each car must be accompanied by the confirmation of the home-ASN that the car corresponds with the national regulation).

** = every car must also correspond to the technical regulations for Standard Production Cars of FIA-CEZ.

*** = every car must correspond to the technical regulations for improved Standard Production Cars of FIA-CEZ

In Italy cars must be equipped with roll cages according App. J/FIA.

Art. 12.2 Events counting towards the Championship

Venues and dates according the FIA CEZ Championship Calendar; see www.cez-motorsport.com).

Should the number of qualifying events organised finally be less than three, the Championship would be considered as not having taken place.

Art. 12.3 Organisation of the events

The events are to be organised according to the FIA Sporting Code and its Appendices and the CEZ Slalom regulations.

Art. 12.4 Classification

At the end of each of the qualifying events a general classification for every group mentioned in Art. 12.1 will be established. For each of the divisions points will be allocated as follows:

25 - 18 - 15 - 12 - 10 - 8 - 6 - 4 - 2 - 1. If there are less than six starters in a group, half points will be allocated.

In case of a dead heat points falling to the ranks concerned will be added up and allocated in equal parts.

The following drivers will be declared winners of the Central European Zone Slalom Championship at the end of the year:

- The driver having scored the most points in Division 1
- The driver having scored the most points in Division 2
- The driver having scored the most points in Division 3

Art. 13. 2025 FIA CENTRAL EUROPEAN ZONE DRIFTING CHAMPIONSHIP

13.1 Eligible Cars

The Championship is reserved for Groups:

- “PRO”
- “PRO2”

All cars based to Article 1.1 of CEZ Technical regulations for Drifting.

- Only cars with rear-wheel drive can enter the race.
- Cars belonging to the group “PRO” and “PRO2” must undergo the obligatory sports cars testing by ASN.

13.2 Events counting towards the Championship

Venues and dates according the FIA CEZ Championship Calendar; see www.cez-motorsport.com).

No additional event after end of February. Should the number of qualifying events organised finally be less than three, the Championship would be considered as not having taken place.

13.3 Organisation of the events

The events are to be organised according to the FIA Sporting Code and its Appendices and the CEZ Drifting regulations.

Drivers will be selected into groups PRO and PRO2 based on qualification results in their season`s first competition by judges.

13.4 Classification

- In qualifying rounds, the points are allocated by referees.
- A Championship points for will be awarded for each Qualifying in each of the 2 groups mentioned in Art. 13.1 according to the following scale:

Place	1	2	3	4-8	9-16	17-32
Points	6	5	4	3	2	1

(If there are less than 6 starters ½ points will be allocated).

- The first 16 drivers (32 - if there will be more than 32 qualifying) with the top rankings will make it to the tandem drives. The winner of the race and other rankings will be determined by the play-off system. The ranking of drivers eliminated in the same round will be based on their ranking after the qualification.
- Points for the title will be awarded for each heat in each of the 2 groups mentioned in Art. 13.1 according to the following scale:

Misto	1	2	3	4	5-8	9-16	17-32
Body	100	88	76	64	48	32	16

(If there are less than 6 starters ½ points will be allocated).

The following drivers will be declared winners of the Central European Zone Drifting Championship at the end of the year:

- The driver having scored the most points in Group “PRO”
- The driver having scored the most points in Group “PRO2”